

Vibrostop MMC



APPLICAZIONI *Applications*

- Supporto antivibrante ed antiurto specifico per impieghi navali: idoneo sia alla protezione degli apparati dagli shock sia all'isolamento di rumore strutturale e vibrazioni eventualmente generati dagli apparati stessi.

- *Specific anti-vibration and anti-shock support for naval use: suitable both for protecting equipment from impacts and for isolating it from structural noise and vibrations potentially generated by the equipment itself.*

MATERIALI *Materials*

- Componente in elastomero: mescola NR (standard) o NBR (a richiesta)
- Componenti in metallo: acciaio inossidabile AISI 304

- *Elastomer component: NR compound (standard) or NBR (on request)*
- *Metal component: AISI type 304 stainless steel*

CARATTERISTICHE *Features*

- Basse frequenze proprie in vibrazione.
- Isolamento del rumore trasmesso per via strutturale.
- Massima deflessione sotto urto pari a 45 mm (S) o 57 mm (M) dalla posizione statica.
- Notevole attenuazione dell'input da prova di shock.
- Massima resistenza alla corrosione.
- Completamente amagnetico.
- Temperatura di utilizzo: -40°/+ 80°C (versione NR).
- Ottima resistenza ad olii e solventi (versione NBR).
- Peso: 1.1 Kg (S) o 2.4 Kg (M)

- *Low resonance frequencies..*
- *Isolation from noise transmitted structurally.*
- *Maximum deflection during shocks equal to 45 mm (S) or 57 mm (M).*
- *Considerable attenuation of shock test input.*
- *Maximum corrosion resistance.*
- *Completely non-magnetic.*
- *Operating temperature: -40° / +80° C (NR version).*
- *Excellent resistance to oils and solvents (NBR version).*
- *Weight: 1.1 kg (S) or 2.4 Kg (M)*

TEST SUPERATI *Tests passed*

- Prova di fatica in vibrazione secondo MIL-STD-167-1 presso i laboratori P&P (2009).
- Prova d'urto secondo allegato G della MIL-S-901-D (similare alla S.T.I.-MM-305) presso CSSN della Marina Militare (2010).
- Prova di isolamento dal rumore strutturale eseguita presso il CETENA (2011)
- Prova di compressione e trazione limite quasi-statica al dinamometro.

- *Vibration fatigue test according to MIL-STD-167-1 at P&P laboratories (2009).*
- *Shock test according to Annex G of MIL-S-901-D (similar to the STI-MM-305) at the CSSN (Naval Support and Testing Centre) of the Italian Navy (2010).*
- *Structural noise isolation test carried out at CETENA (Italian Ship Research Centre) (2011).*
- *Compression and quasi-static tensile test by dynamometer.*

MODELLO <i>Type</i>	DUREZZA <i>Hardness</i> [°ShA]	PORTATA <i>Load</i> min - max [daN]	DEFLESSIONE <i>Deflection</i> [mm]	FREQUENZA PROPRIA <i>Natural</i> Frequency [Hz]	RIGIDEZZA STATICA <i>Static</i> Stiffness [daN/mm]
MMC-S-N 30	45±3	15 - 30	3.5 - 6.5	9 - 6.5	5
MMC-S-N 50	55±3	30 - 50	4 - 6.5	8 - 6	8
MMC-S-N 80	65±3	50 - 80	3.5 - 6.5	7.5 - 6	11
MMC-M-N 100	45±3	50 - 100	5.5 - 10.5	7 - 5	9.5
MMC-M-N 160	55±3	100 - 160	5.5 - 10	6.5 - 5	17
MMC-M-N 230	65±3	160 - 230	5 - 9	7 - 5.5	28

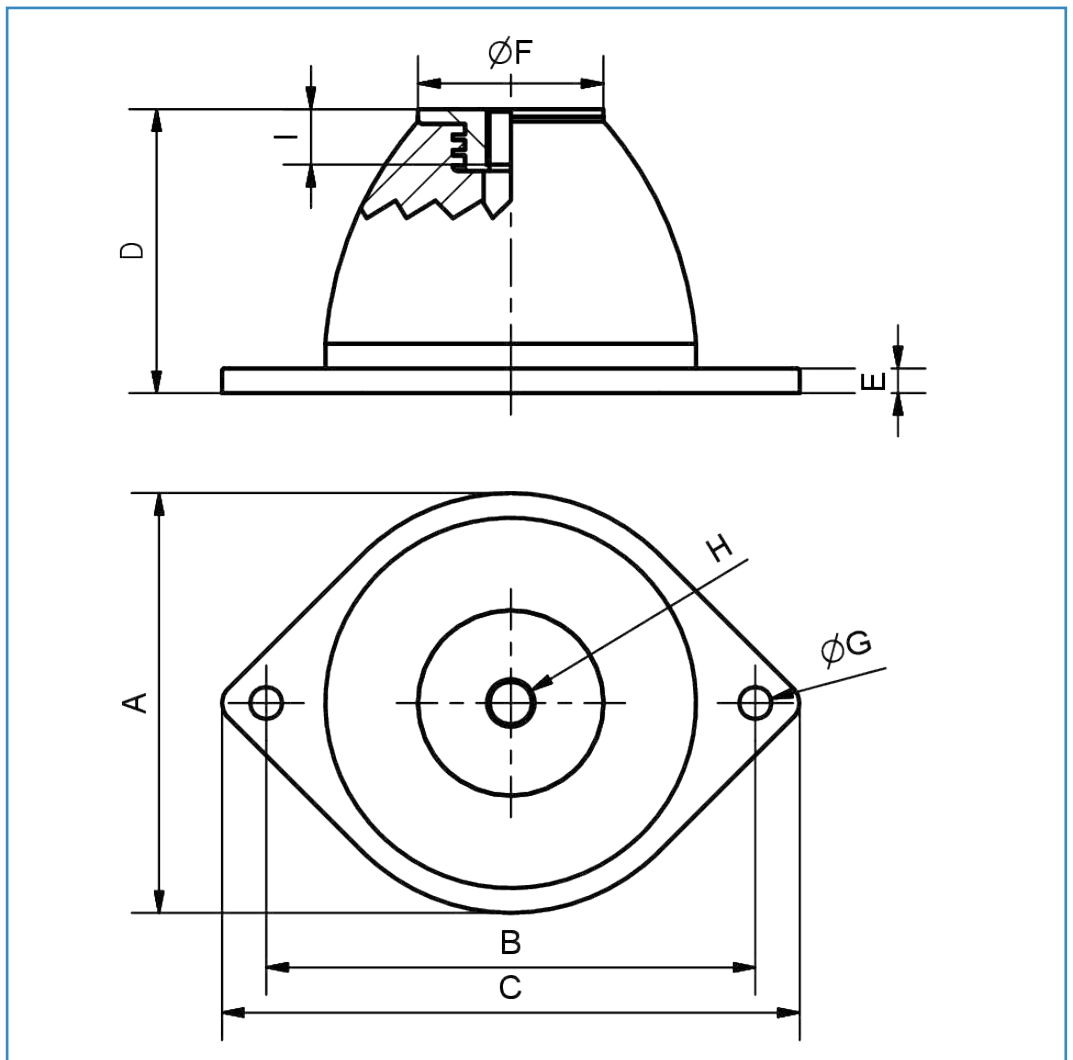

Dimensioni indicative

Dimensions for reference only

MODELLO <i>Type</i>	A [mm]	B [mm]	C [mm]	D [mm]	E [mm]	ØF [mm]	ØG [mm]	H [mm]	I [mm]
MMC-S-N	135	160	184	78	8	55	13	M12	15
MMC-M-N	170	198	234	115	10	75	13	M20	20

CONFIGURAZIONI TIPICHE *Typical layout*

BASE

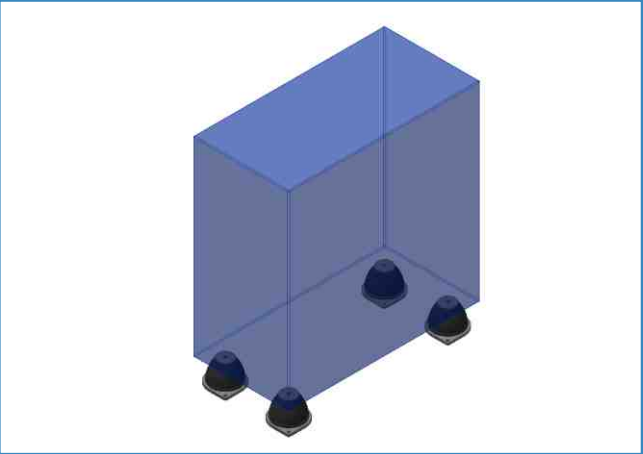

BASE and STABILIZERS

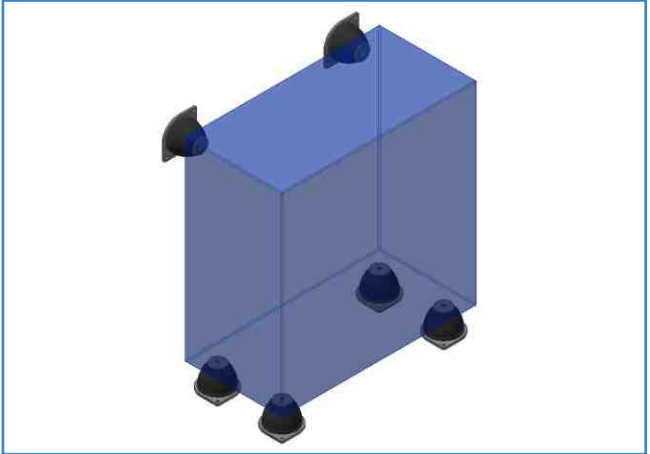

Curva forza-deflessione statica *Static force-deflection curve*

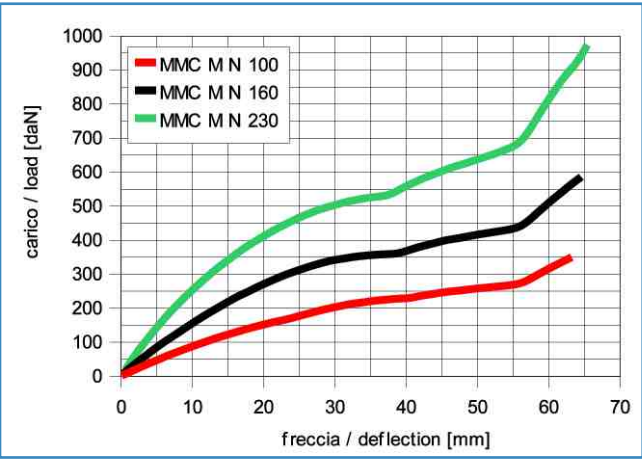
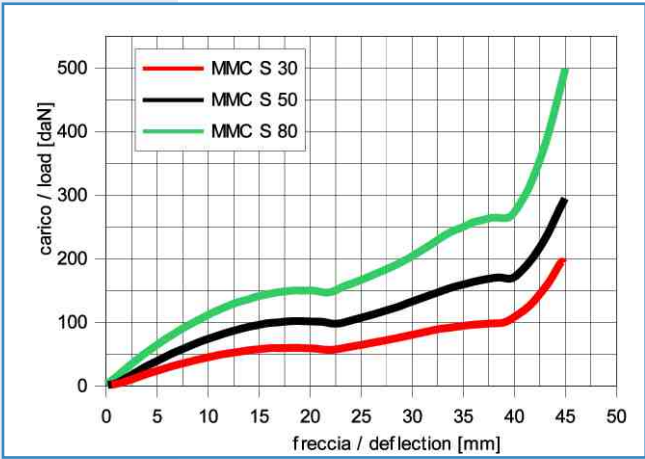

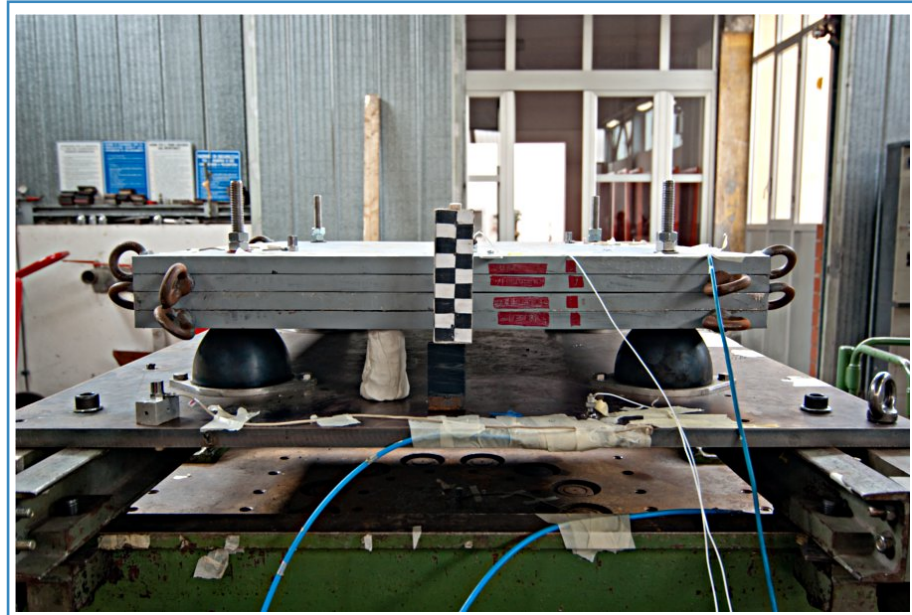

Immagini delle prove svolte secondo MIL-S-901 D (S.T.I. MM-305) - a sinistra prima dell'urto, a destra nel momento del massimo allungamento dopo l'impatto
 Images of the tests carried out according to MIL-S-901 D (STI MM-305) - On the left before impact, on the right at the moment of the maximum elongation after impact



Grafico della prova di resistenza allo shock secondo MIL-S-901 D (o STI MM-305) - INPUT

Diagram of the shock resistance test according to MIL-S-901 D (or STI MM-305) - INPUT

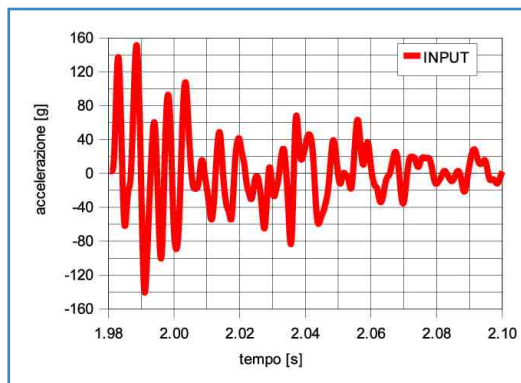

Curve caratteristiche indicative



Grafico della prova di resistenza allo shock secondo MIL-S-901 D (o STI MM 305) - OUTPUT

Diagram of the shock resistance test according to MIL-S-901 D (or STI MM-305) - OUTPUT

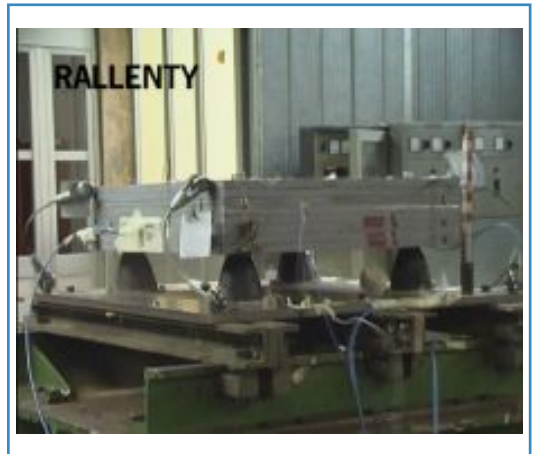
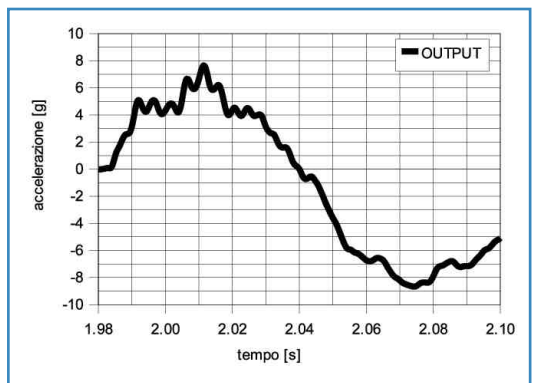

Performance characteristics for reference only

I dati si riferiscono alla configurazione testata e non sono generalizzabili ad altre applicazioni.
 Data refer to the tested configuration and cannot be used for other applications.

Misura dell'isolamento dal rumore strutturale
Measuring isolation from structure-borne noise

BASSE FREQUENZE
Low frequency

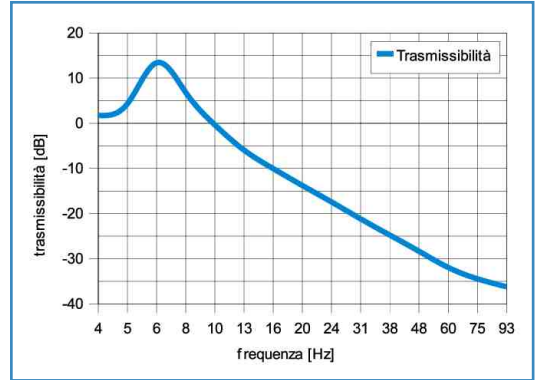
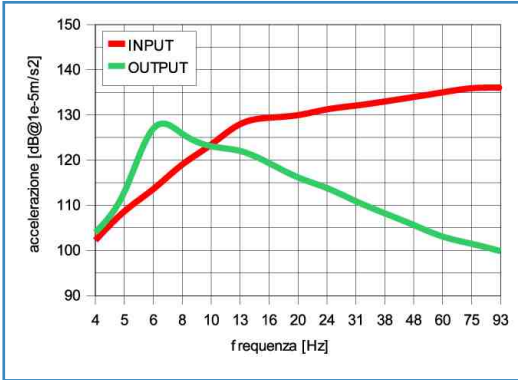

MEDIO-ALTE FREQUENZE
Mid-high frequencies

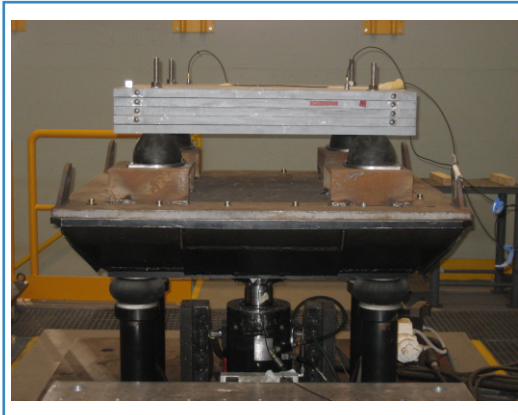

Grafico della prova di fatica in vibrazione secondo MIL-STD-167-1
Diagram of the vibration fatigue test according to MIL-STD.167-1

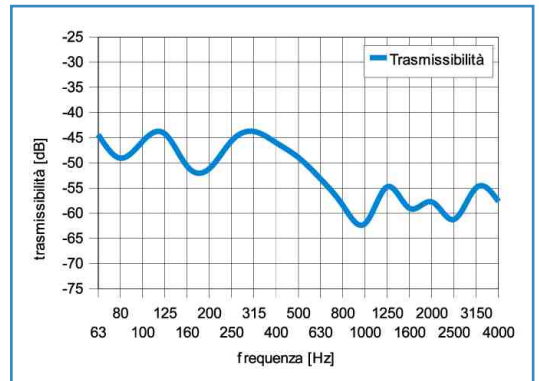
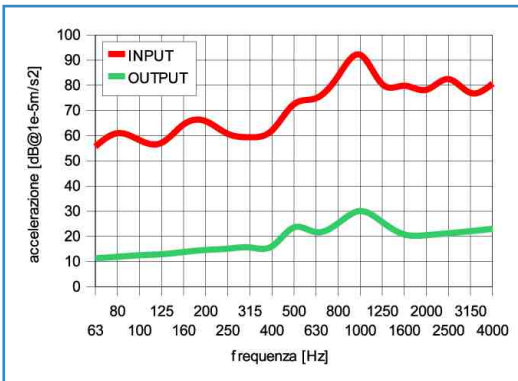

Curve caratteristiche indicative

Performance characteristics for reference only